

### ESP32 LED Pixel (WS2812) Driver Board - MLP201167

#### Features and Benefits

- Onboard ESP32 module with WLED installed
- 5V or 12V Operation
- 4 Channel Data Outputs
- 4off 5V data outputs to LED pixels
- Screw terminal connections
- Analogue audio input option
- IR Receiver
- Push Button as used by WLED
- Programmable status LED
- USB port for programming (CH340)

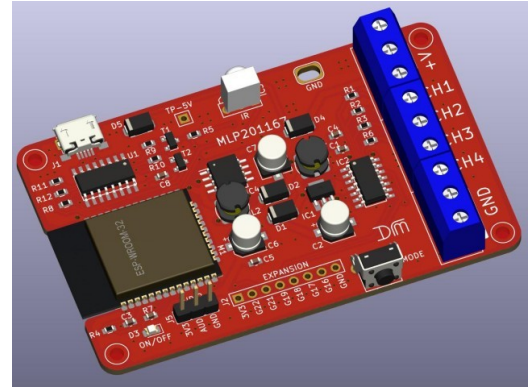

#### Product Details

The MLP201167 provides a solution for connecting WS2812 or similar LED pixel strips to the popular ESP32 Wi-Fi modules. An on-board 74HCT125 line driver provides a 5V P/P output from the normal 3.3V outputs supplied by the ESP32.

Supply voltage range.

A Sound reactive option is possible via a 3 pin header for use with an external analogue microphone board, the microphone is then connected to the ESP32 analogue input.

A USB port is provided for programming using a CH340 USB to serial chip.

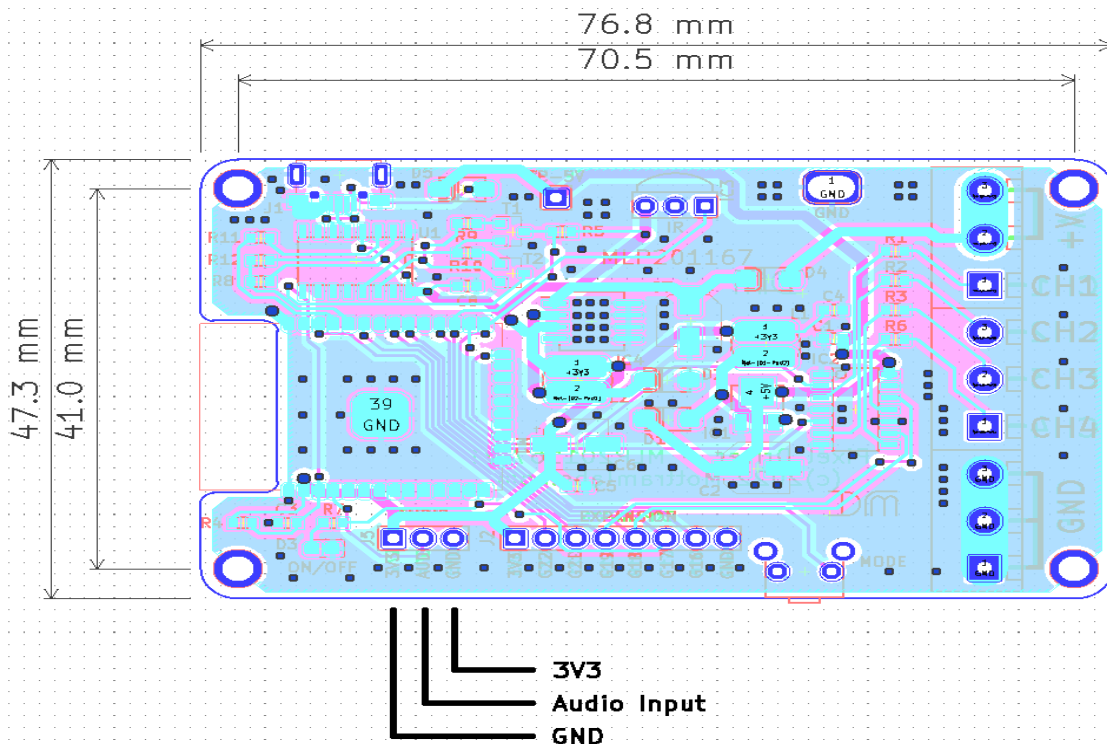

## MLP201167 - Schematic

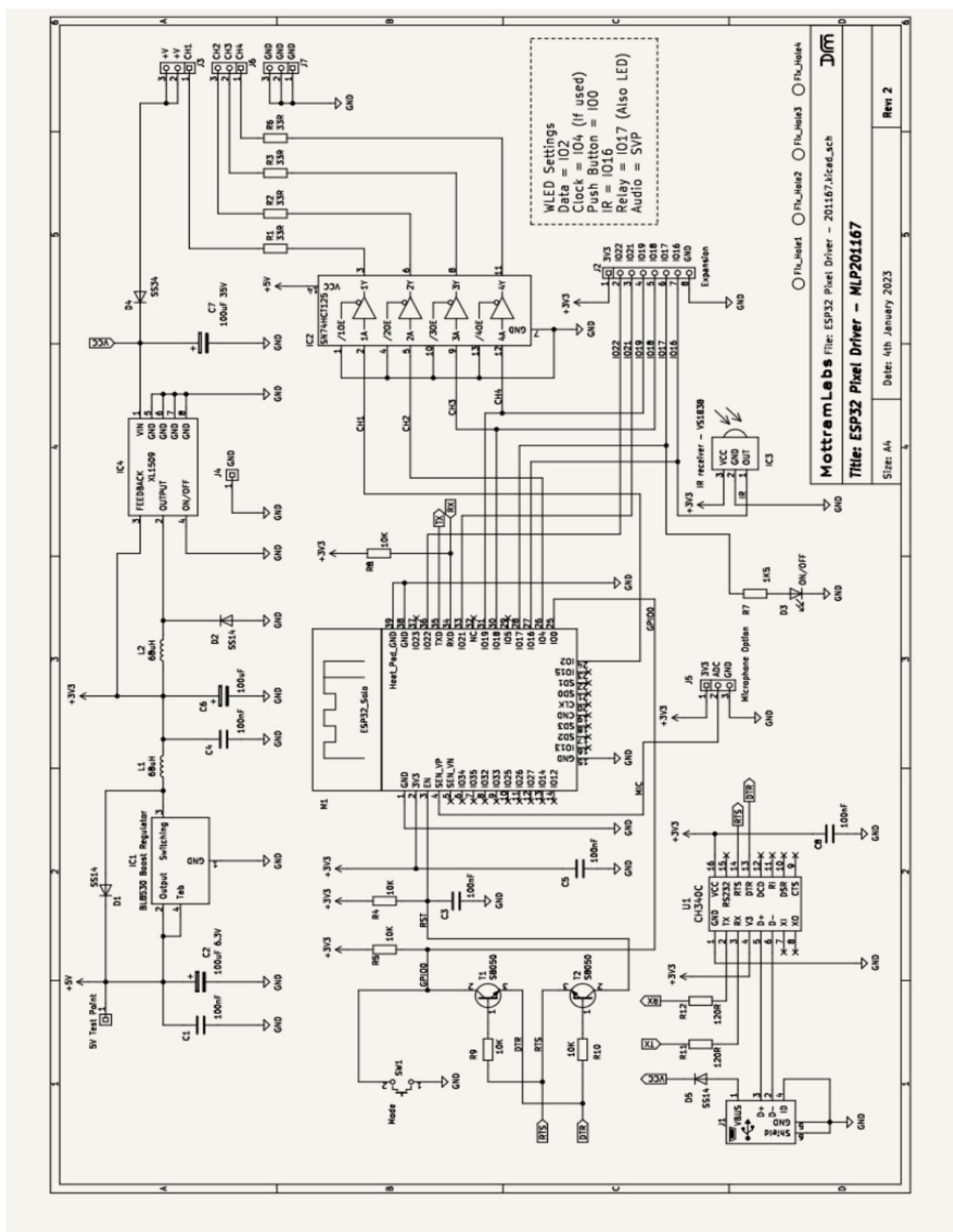

## Software – WLED

Although the board can work with a range of software one of the most popular and feature rich is WLED. Below are some links to the WLED project page and a fork “WLED Sound Reactive”. This version adds as the name suggests sound reactive modes, this version requires an external audio input. The simplest way is to add a microphone board to the ESP32’s analogue input.

---

## Flashing Tool

**ESPHome-Flasher** is a python utility for programming the Wemos D1 Mini

<https://github.com/esphome/ESPHome-Flasher>

---

## WLED

**WLED Github Page**

<https://github.com/Aircoookie/WLED>

**WLED Releases**

<https://github.com/Aircoookie/WLED/releases>

**WLED Web Installer Tool**

<https://install.wled.me/>

---

## Sound Reactive WLED

**Sound Reactive WLED Releases**

<https://github.com/atuline/WLED/releases>

**Sound Reactive Wiki**

<https://github.com/atuline/WLED/wiki>

**Audio connection Options**

<https://github.com/atuline/WLED/wiki/Analog-Audio-Input-Options>

---