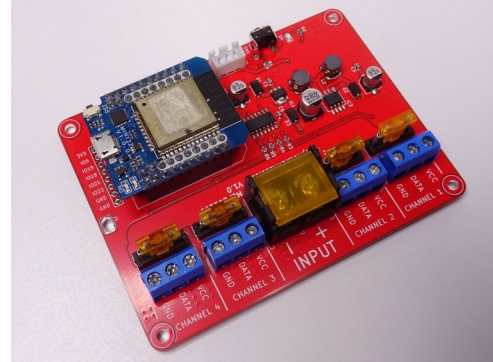

ESP32 LED Pixel (WS2812) Driver Board - **MLP201199****Features and Benefits**

- Supports Wemos ESP32 boards
- 5V to 24V Operation
- On-board regulator powers the Wemos board
- 4 Channel Data Outputs
- 5V data output to LED pixels
- On-board fuse per channel 5A (max 10A)
- Screw terminal connections
- Analogue audio input option

**Product Details**

The MLP201199 provides a solution for connecting WS2812 or similar LED pixel strips to the popular Wemos D1 Mini ESP32 Wi-Fi modules. An on-board 74HCT125 line driver provides a 5V P/P output from the normal 3.3V outputs supplied by the ESP32 & ESP8266 chips.

The board provides a 5A blade type fuses (Mini Low Profile), one per channel output. The board can be used with either 5V or 24V LED strips when using the appropriate power supply. The board does not regulate the LED's power supply so the power supply used must match the LED's used.

A Sound reactive option is possible via a 3 pin header for use with an external analogue microphone board, the microphone is then connected to the Wemos D1 Mini's analogue input.

Also a push button for use with WLED firmware.

Peripheral Connections and I/O Mapping	
Function	ESP32
Channel 1	IO16
Channel 2	IO17
Channel 3	IO2
Channel 4	IO4
Push Button Switch	IO0
LED	IO18
Audio	SVP

## MLP201199 - Connections

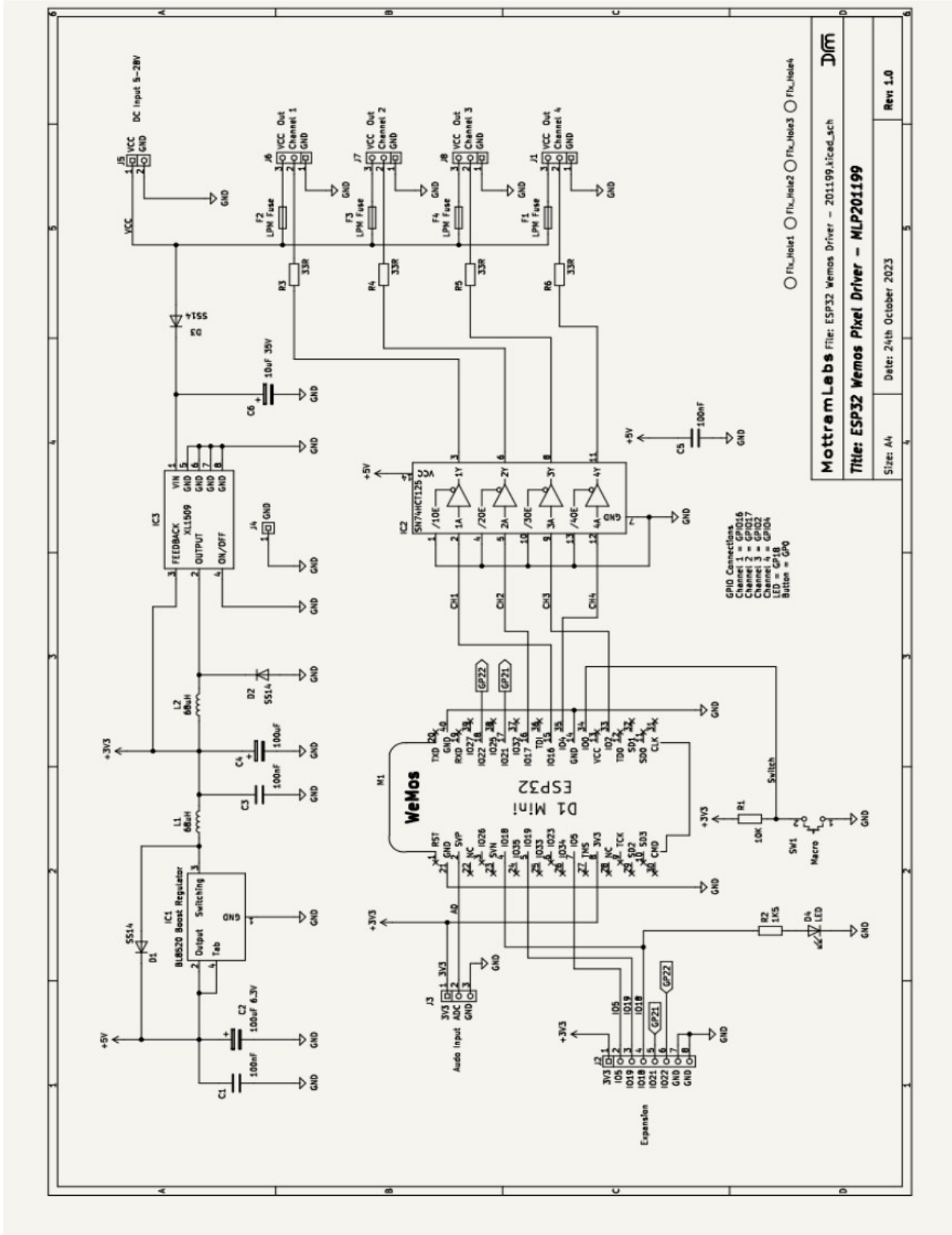

## Software – WLED

Although the board can work with a range of software one of the most popular and feature rich is WLED. Below are some links to the WLED project page and a fork “WLED Sound Reactive”. This version adds as the name suggests sound reactive modes, this version requires an external audio input. The simplest way is to add a microphone board to the Wemos D1 Mini’s analogue input.

---

## Flashing Tool

**ESPHome-Flasher** is a python utility for programming the Wemos D1 Mini

<https://github.com/esphome/ESPHome-Flasher>

---

## WLED

**WLED Github Page**

<https://github.com/Aircoookie/WLED>

**WLED Releases**

<https://github.com/Aircoookie/WLED/releases>

---

## Sound Reactive WLED

**Sound Reactive WLED Releases**

<https://github.com/atuline/WLED/releases>

**Sound Reactive Wiki**

<https://github.com/atuline/WLED/wiki>

**Audio connection Options**

<https://github.com/atuline/WLED/wiki/Analog-Audio-Input-Options>

---